



Technical Rider General

-
- **Rebel Monster uses In-Ear Monitoring! No exceptions!**
 - **Monitor Mix: Band! FOH Mix: FOH-Tech.**
 - **Equipment for In-Ear Monitoring and Mics are provided by the Band.**
 - **Rebel Monster uses E-Drums and no Amps!! FOH system must deliver sufficient power for this purpose, even in small venues.**
 - **Drumfill: Drums + FOH Mix. Monitors: FOH Mix (for first row listeners and backup for In-Ear Monitoring)**
 - **The following pages show the signal-path and monitoring concept. For further details or questions please contact:**

Oliver Noerdlinger: (0) 157 8344 6934



**Technical Rider
Stage**

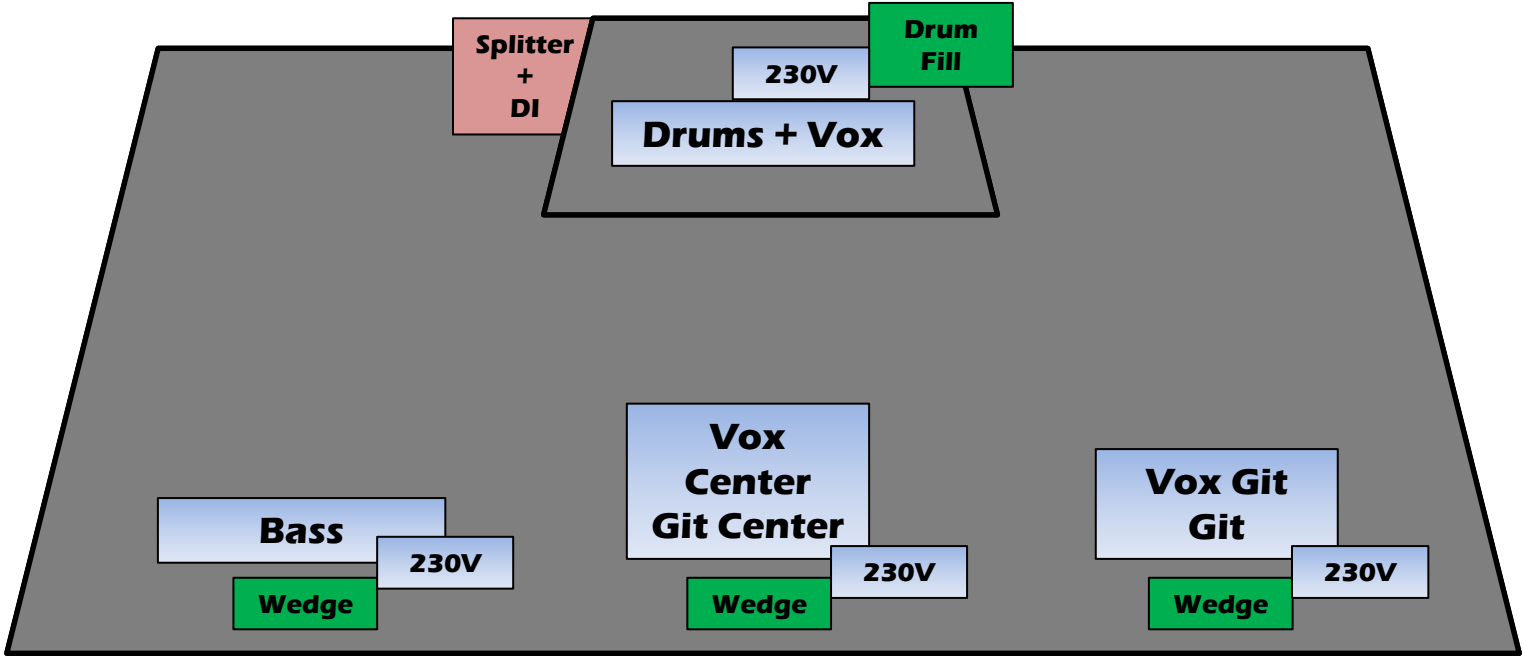



Technical Rider Signal Flow

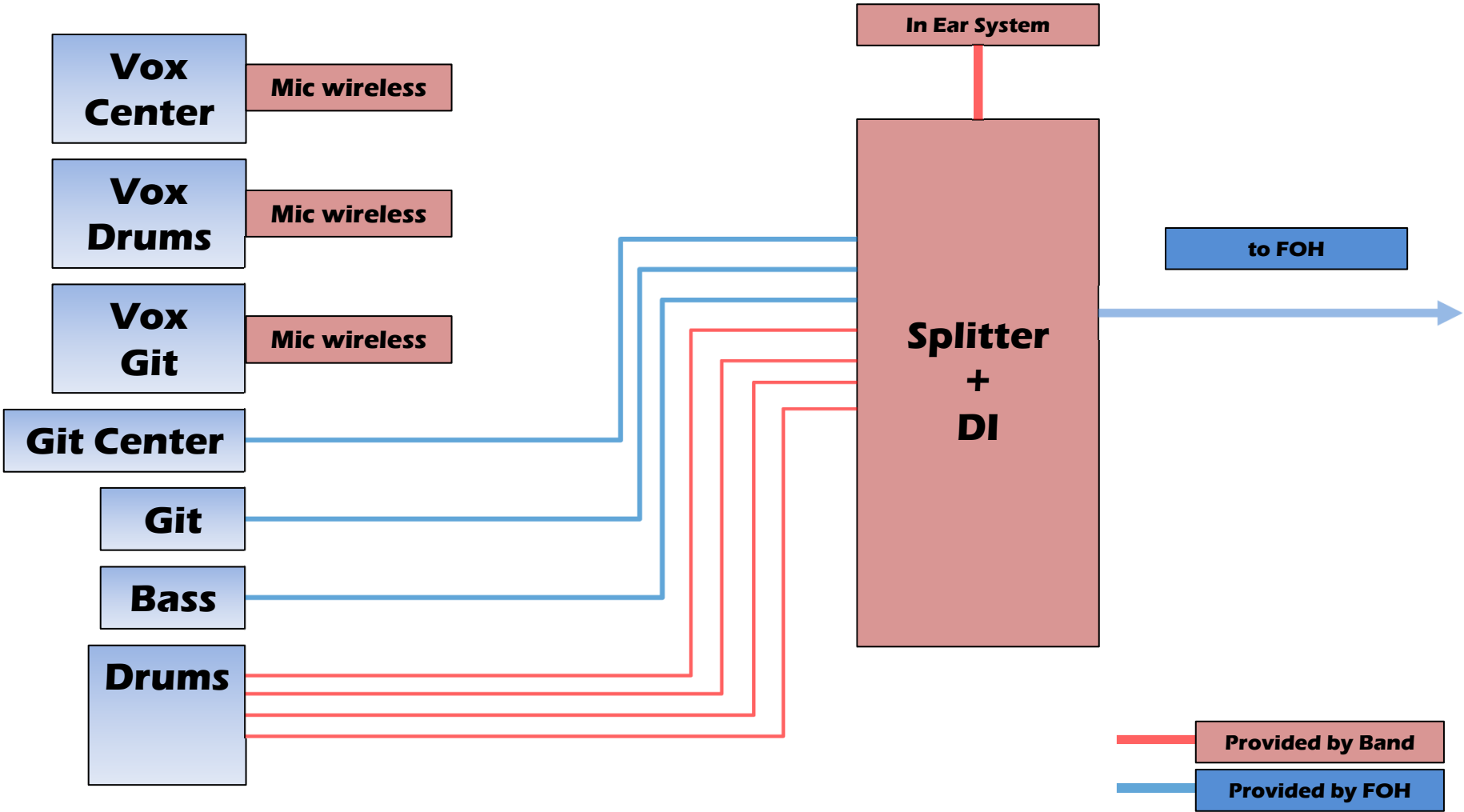

Technical Rider Splitter + DI

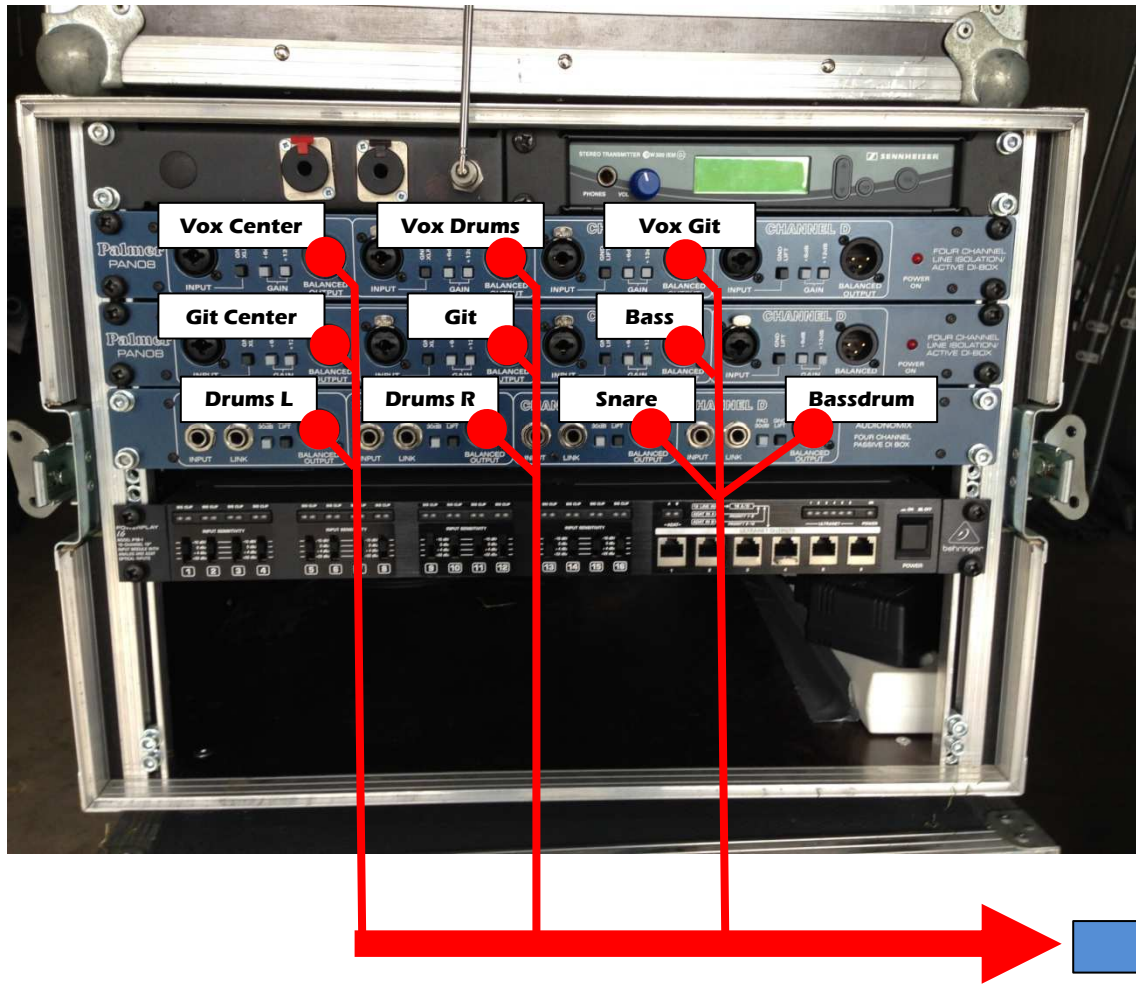



**Technical Rider
Stage Setup**

**Backdrop:
4m x 3m**

**No Lights,
Scanners or
Moving Heads
lower than 2m!**



**No Lights,
Scanners or
Moving Heads
lower than 2m!**

**Rollup:
2m x 2m**



**Rollup:
2m x 2m**

